



July 2010:
Instructions for Deck Modifications

Included with these instructions is the City of Farmington Hills requirement for wood deck construction.

Attached are seven (7) drawings defining the deck construction requirements for the River Pines Condominium Association.

Please refer to the River Pines web site,

www.riverpinescondominiums.com

and look under the menu item “rules and regulations – deck / patio” for further instructions and clarification.

On sheet #1 of the drawings show the following –

- Your unit address, unit number, building number
- Owners name and phone number
- Contractors name and phone number
- Show where your deck is to be located by drawing an outline of what is planned. Show dimensions for length, width and height of the deck.

You will need five (5) copies of these drawings plus additional drawings for irregular shaped decks or any special details you have planned:

- 1 – To be submitted with your modification request
- 2 – City of Farmington Hills Building Dept
- 1 – For your construction contractor
- 1 – For your records

Submit a River Pines Modification Request and 1 copy of all drawings to McShane and Associates for review and approval by the Board of Directors.

While you are waiting for approval from the Board of Directors you should contact the City of Farmington Hills building department and obtain a building permit application. You can also obtain an application from their web site at:

<http://www.fhgov.com/ReferenceDesk/Forms/PCD> BuildingPermitApp.pdf.

You will need a building permit for new construction as well as the replacement of wood on an existing deck.

Once you receive approval from the Board of Directors, take 2 copies of the drawings and the completed building permit application to the City of Farmington Hills Building Department. The Building Dept. is located at 11 mile road and Orchard Lake road.

A copy of the building permit must be provided to the River Pines Site Manager Bob Goodman before beginning construction. He can be reached by calling 248-756-3888.

The City of Farmington Hills requirements on deck construction allows for skirting under the deck. However, the River Pines practice or policy does not allow skirting or lattice work surrounding the underside of any deck.



DEPARTMENT OF PLANNING AND
COMMUNITY DEVELOPMENT

City of Farmington Hills

REQUIREMENTS FOR WOOD DECK CONSTRUCTION

1. Building permits are required prior to constructing wood decks. When making application for a permit, please provide the following information:
 - A. Two (2) site plans that indicate the location of the deck (size and shape) and the distance from **property lines and easements**.
 - B. Two sets of working drawings that show structural details.
 - C. Completed building permit application.

2. **Minimum Required Inspections.**
 - A. Post hole inspection (size and depth).
 - B. Final Inspection (when all work is complete).

3. **Footing (post holes) and Framing** Posts are to be set a minimum of 42" below grade or to virgin soil if necessary. Spacing of posts must provide adequate structural support. Joist spacing and span lengths must provide adequate structural support. Post and joist location and size must be noted on the drawings. Ledger boards against brick veneer must be through bolted to the rim joist with a minimum ½" bolt spaced not greater than 24" apart. Beams must be bolted to posts or rest on top of posts using a galvanized metal connector. Joists that attach to the sides of beams or ledger boards must be secured with appropriately sized joist hangers. Finished grade under and around the deck must slope away from the deck and house and provide positive drainage.

4. **Setbacks from Property Lines** Wood decks cannot encroach upon any easement, right-of-way, or the minimum setback required by the zoning ordinance.

5. **Framing Material** All wood exposed to the weather must be pressure treated or of a naturally durable species (redwood, cedar, etc.). All wood in contact with the ground must be labelled "Ground Contact".

Administration
248.871.2550
248.871.2521 Fax

Building Division
248.871.2450
248.871.2451 Fax

Community Development
248.871.2549
248.871.2521 Fax

Planning Office
248.871.2540
248.871.2521 Fax

Zoning and Code Enforcement
248.871.2520
248.871.2521 Fax

6. **Framing Fasteners** All nails, bolts less than ½" in diameter, screws, and nails shall be of zinc, zinc coated, stainless steel, galvanized, or other approved corrosion resistive material.
7. **Handrails and Guardrails** Handrails are required on stairs with three or more risers (two treads). Handrails are to be not less than 34" nor more than 38" in height measured vertically from the nosing of the treads. **Handrails must be graspable with a cross-sectional dimension not to exceed 2 5/8"**. Handrail ends shall be returned to the wall or post adjacent to the handrail. Guardrails are required on decks with the walking surface 30" or more above the adjacent grade. Guardrails are to be a minimum of 36" above the walking surface. Vertical enclosures (spindles) must be spaced so as to not allow the passage of a sphere 4" or more in diameter.
8. **Stairs** Stair risers must be no more than 8 ¼" in height and must be equal throughout the length of each stair. Stair treads must be at least 9" in depth with a 1" nosing. Tread depth shall be measured from nosing to nosing and must be equal throughout the length of each stair.
9. **Ground Cover** consisting of sheet plastic and stone/gravel is **recommended** under all decks.

Skirting When skirting is to be installed around the perimeter of the deck, the final approval must be obtained prior to the installation.

RIVER PINES OF FARMINGTON CONDOMINIUM ASSOCIATION

GUIDELINES FOR CONSTRUCTION OF NEW WOOD DECKS

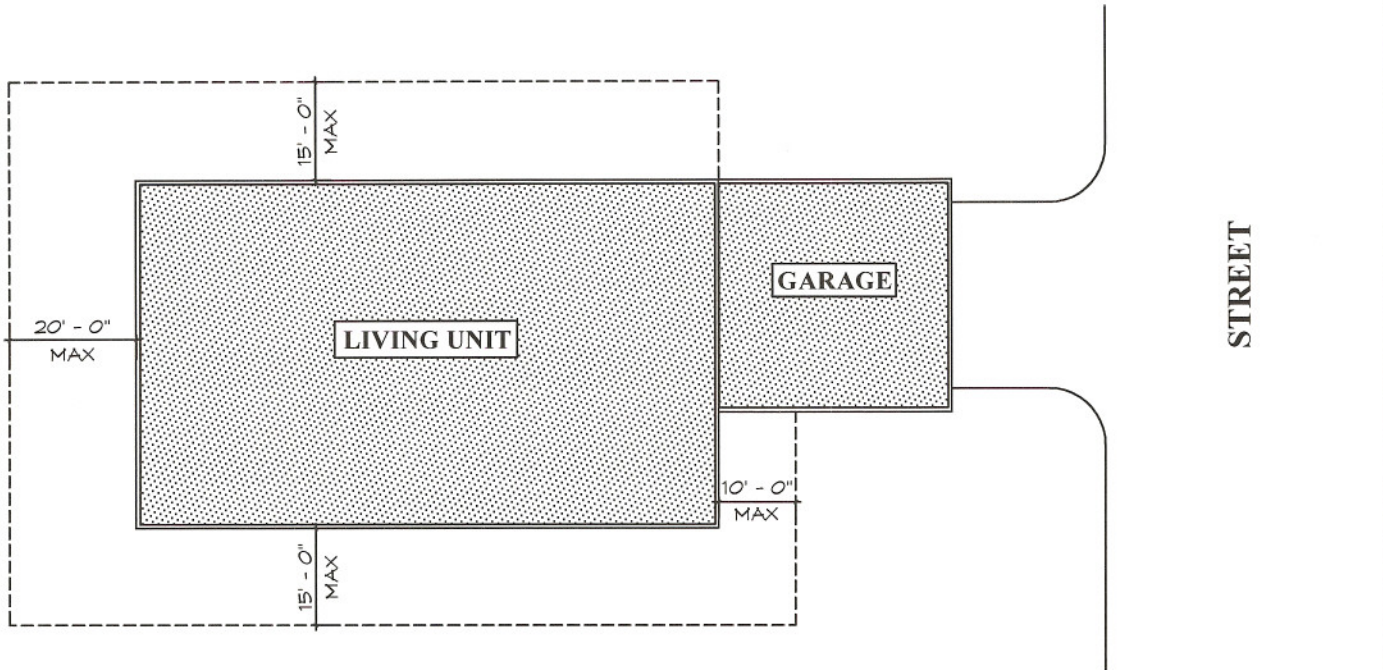

LIVING UNIT FOOTPRINT

LOCATE AREA OF PROPOSED WOOD DECK ON THIS DRAWING

GENERAL NOTES

THESE NOTES & ATTACHED DRAWINGS ARE INTENDED TO BE TYPICAL, REQUIRED &/OR RECOMMENDED

ALL WOOD MEMBERS TO BE PRESSURE TREATED UNLESS ALTERNATE MATERIAL IS APPROVED BY THE BOARD

SCREWS & NAILS MUST BE APPROVED IN THE FARMINGTON HILLS BUILDING CODE FOR USE WITH TREATED WOOD

MAX. STAIR RISER 8 1/4"
MIN. STAIR TREAD 9"

1" ROCK 2" DEEP TO BE PLACED BELOW DECK ON #6 BLACK PLASTIC SHEET
SLOPE GRADE BELOW DECK 1/4" PER FOOT MIN. AWAY FROM LIVING UNIT

DECK STAIN TO BE "SHERWIN WILLIAMS" SEMI TRANSPARENT A17NI CEDAR TUNE OR
DECKSCAPES 3029 EMBER COLOR

RIVER PINES OF FARMINGTON CONDOMINIUM ASSOCIATION

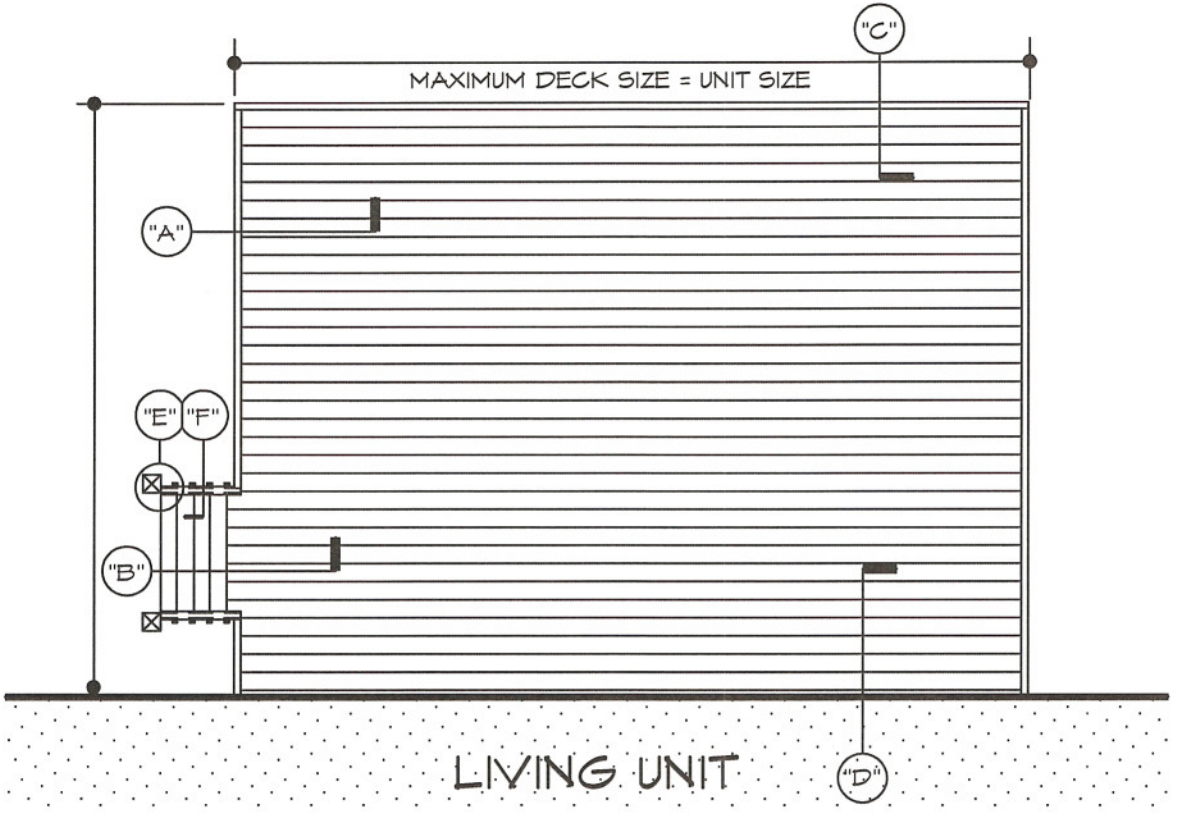

DECK SITE PLAN

SEE DETAILS ON SHEETS 4 THRU 7

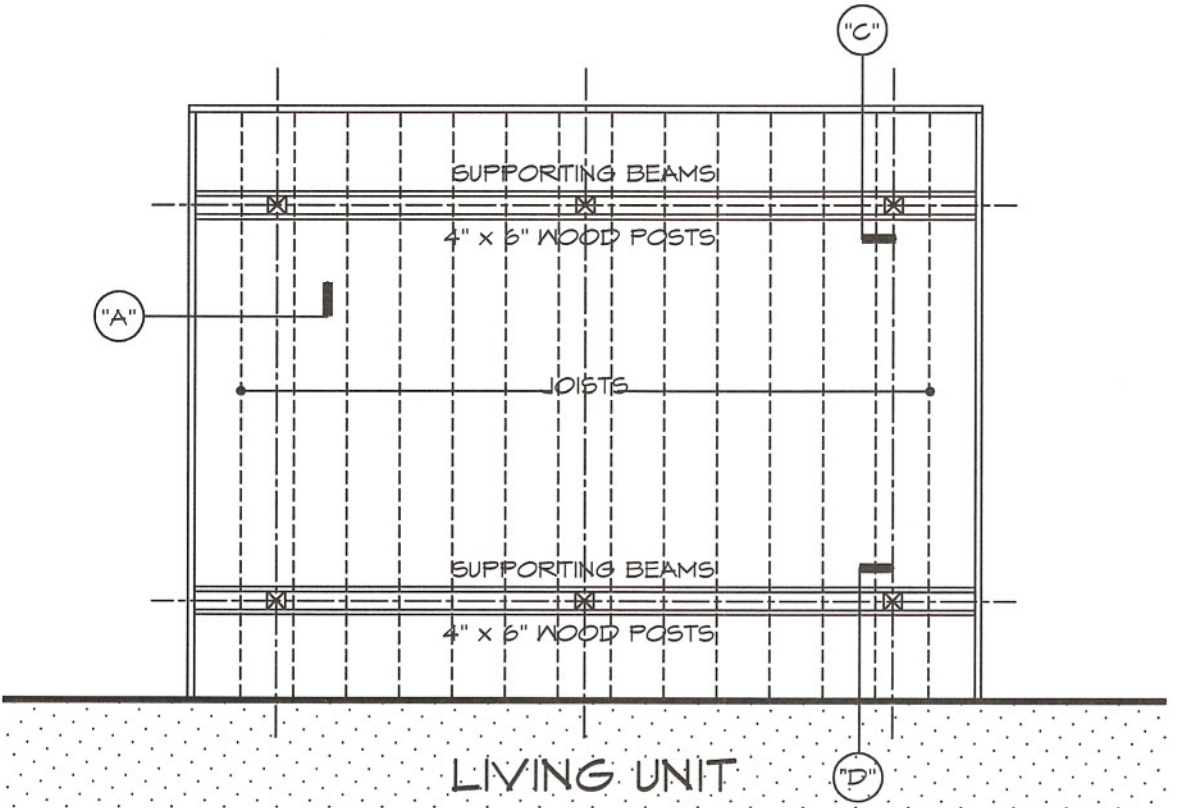

TYPICAL DECK FRAMING

RIVER PINES OF FARMINGTON
CONDOMINIUM ASSOCIATION

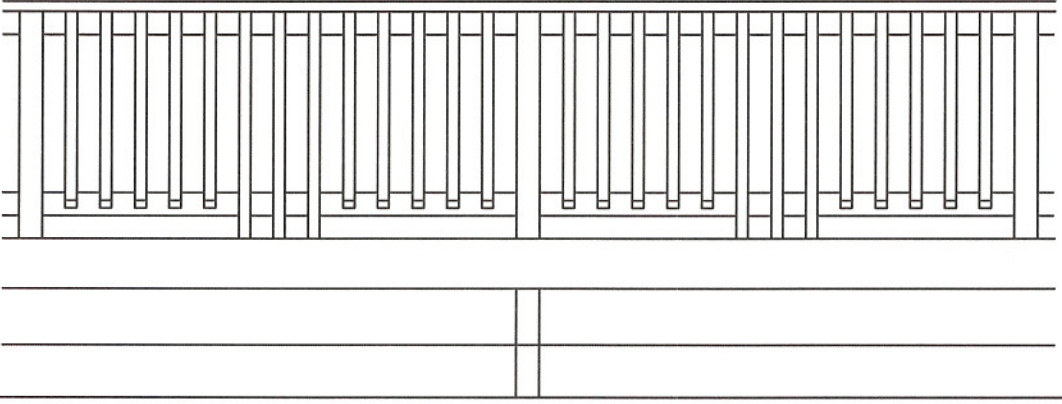

RAILING OPTION "1"

ONLY 2" x 2" BALUSTERS MAY BE USED
4" MAX CLEAR SPACE BETWEEN BALUSTERS & AT DECK LEVEL

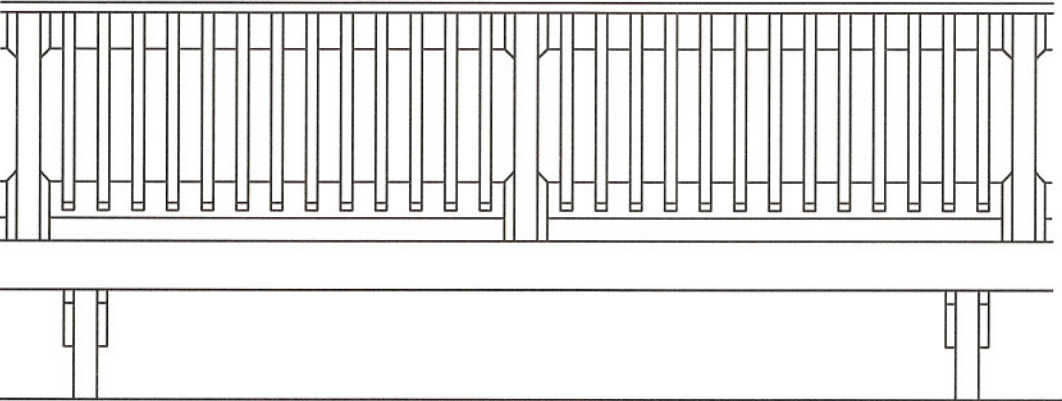

RAILING OPTION "2"

RIVER PINES OF FARMINGTON CONDOMINIUM ASSOCIATION

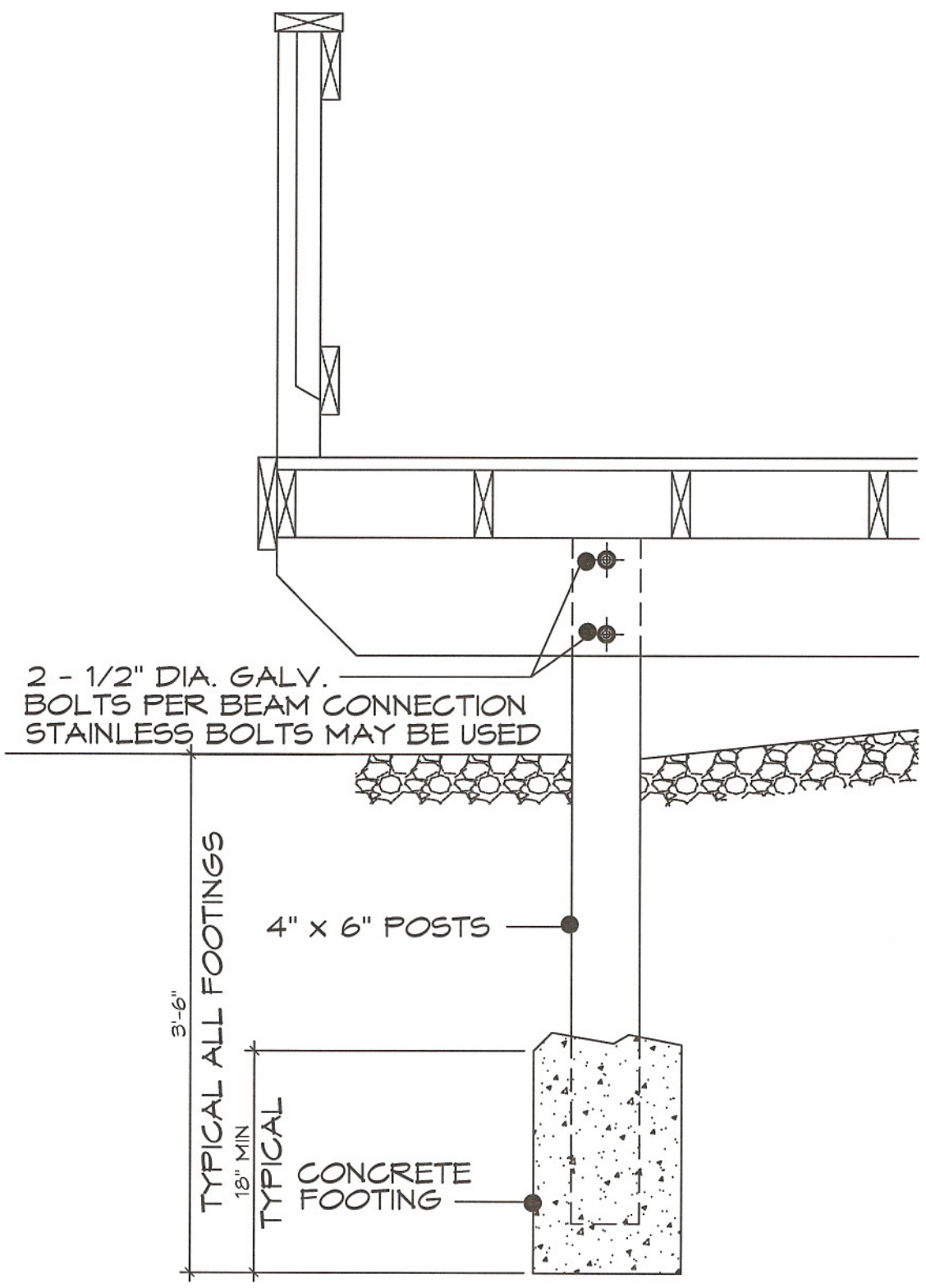

DETAIL "A" SHEET 4 OF 7

RIVER PINES OF FARMINGTON CONDOMINIUM ASSOCIATION

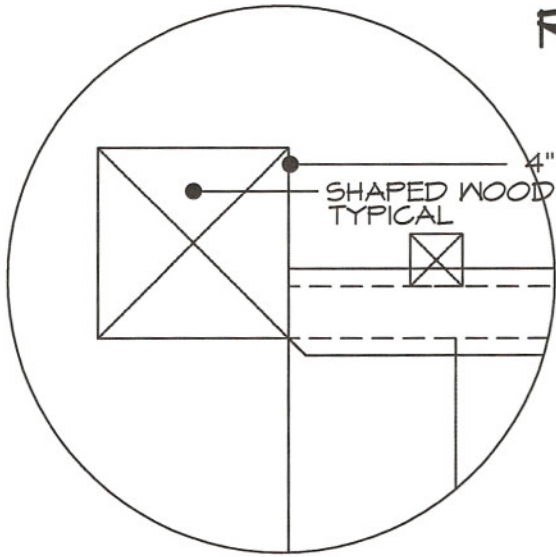

DETAIL "E"

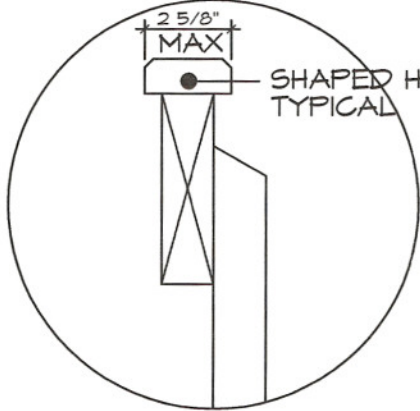
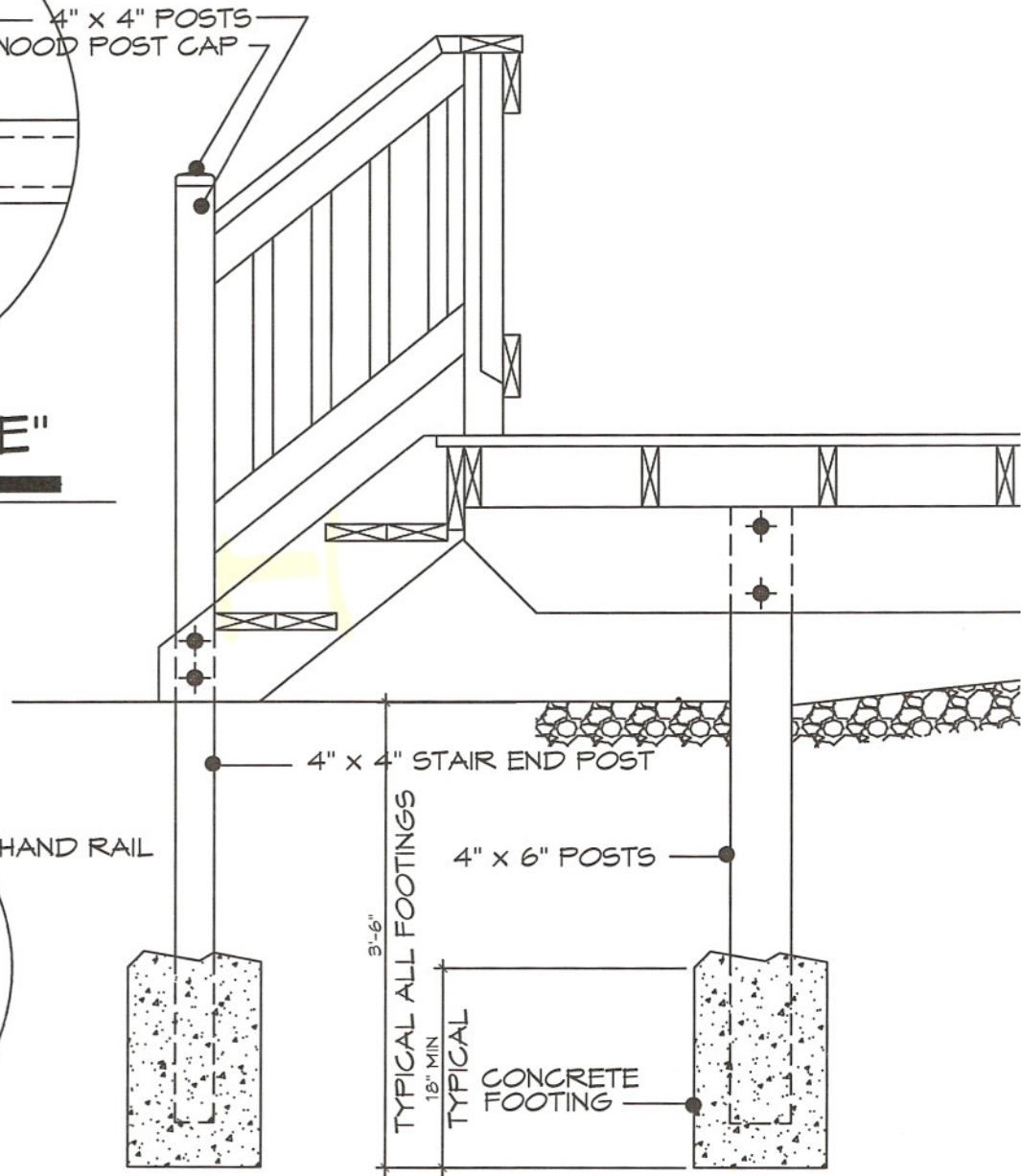

DETAIL "F"

DETAIL "B"

SHEET 5 of 7

RIVER PINES OF FARMINGTON CONDOMINIUM ASSOCIATION

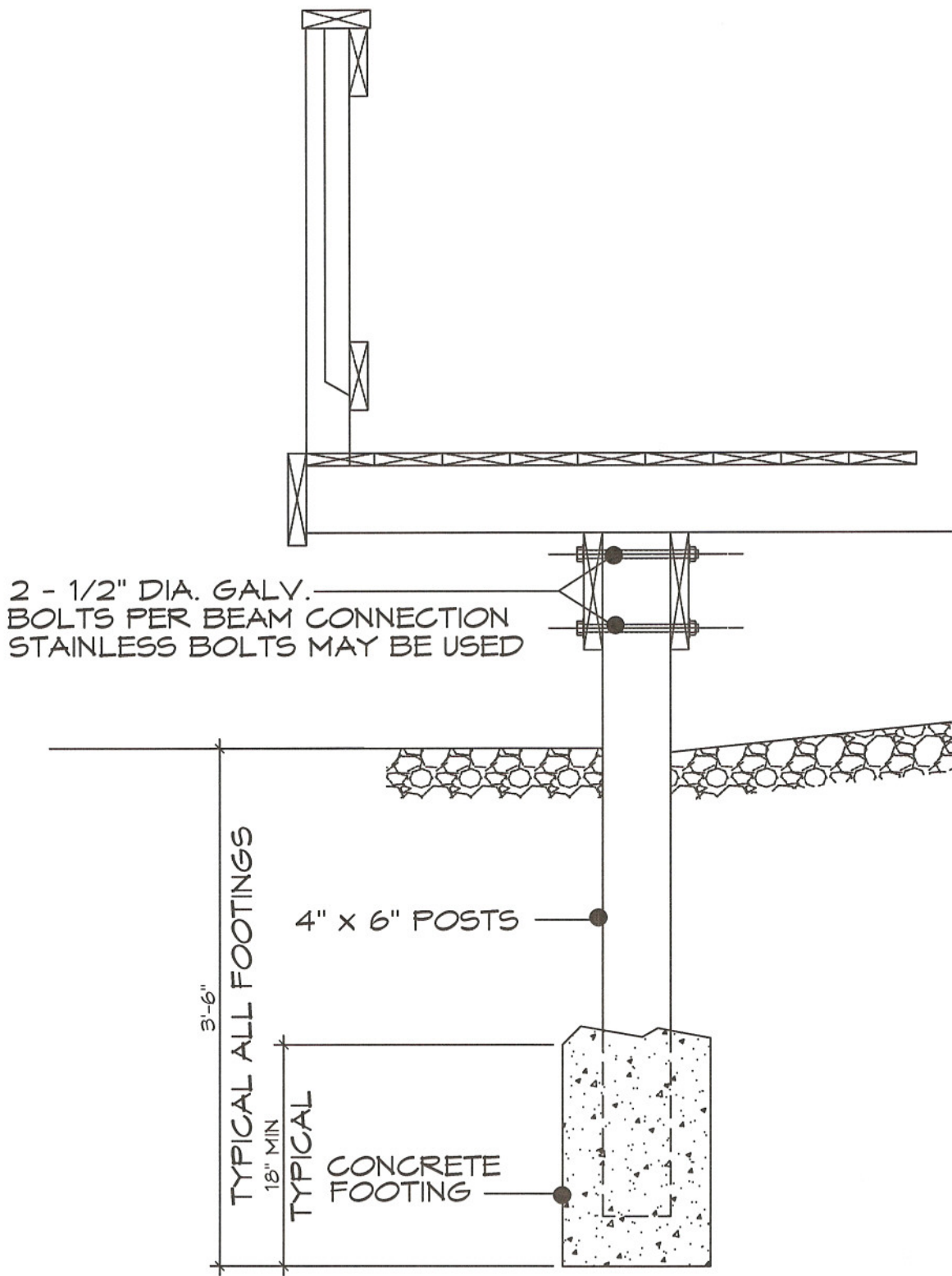

DETAIL "C"

SHEET 6 of 7

RIVER PINES OF FARMINGTON CONDOMINIUM ASSOCIATION

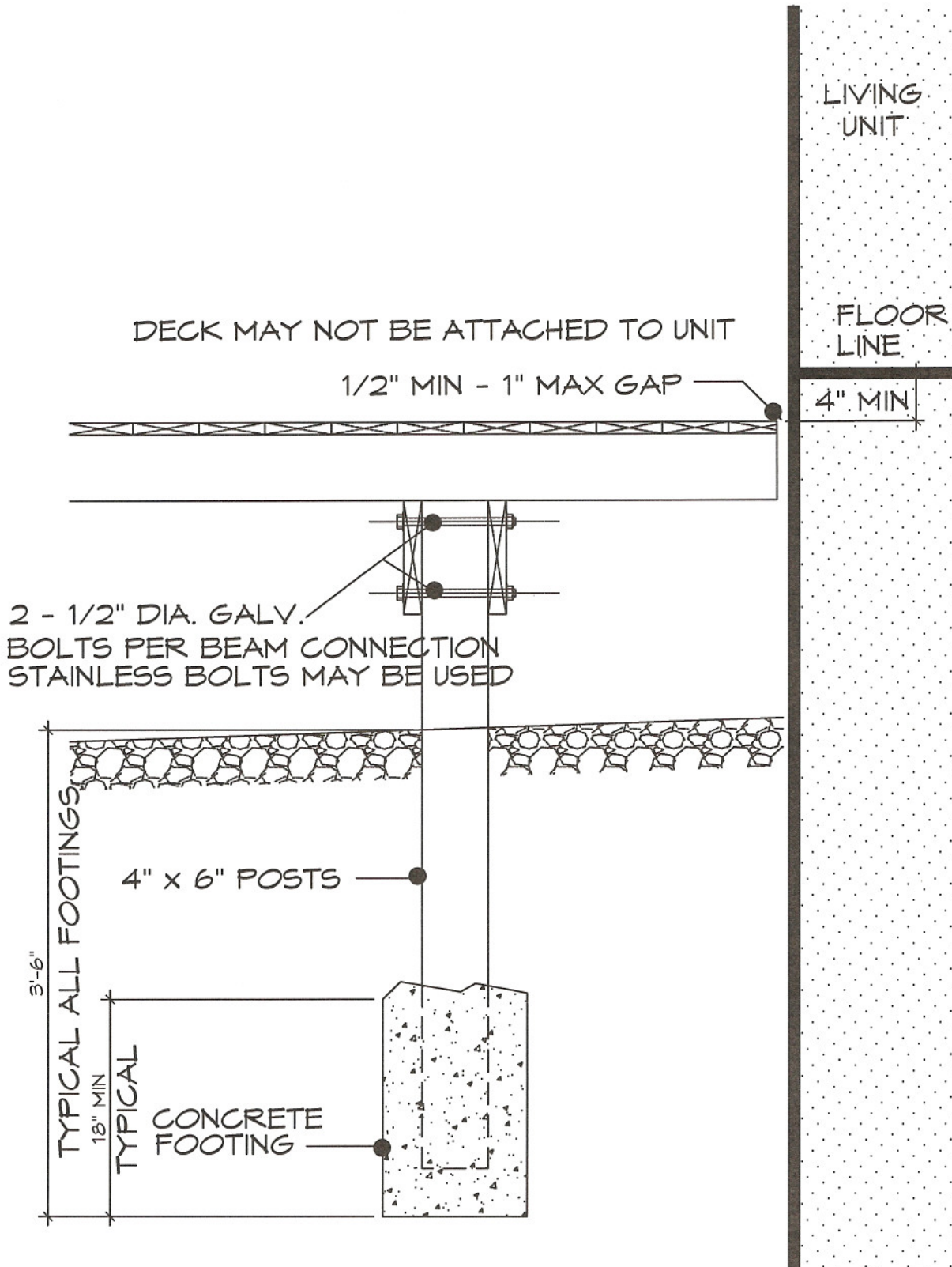

DETAIL "D"